

Smart Pressure Transmitter



Registered No. 325327

Type ME 71

General Description

The type ME 71 pressure transmitter uses a capacitance type sensor and modern micro-processor technology. It is ideally suited for measuring positive and negative gage pressure in applications where a high degree of accuracy is required. It is optionally available in versions certified for use in hazardous locations.

Features

- robust, wear resistant sensor
- high resistance to corrosion
- high degree of functionality
- excellent long term stability
- low hysteresis
- not affected by fouling of pressure chambers
- capacitance type silicon sensor
- microprocessor technology

Principles of Operation

The type ME 71 pressure transmitter uses a silicon capacitance sensor with a bridge measuring circuit, the output of which changes when the pressure changes.

Modern microprocessor technology is used to convert the bridge output to a standard 4-20 mA signal, which permits the measured value to be transmitted over long distances. A HART® interface is also available, using an optional communication module installed in the transmitter. With the HART® interface, digitally transmitted pressure measurements, as well as the transmitter's set-up data can be read very accurately by simply connecting a compatible terminal device at any point along the length of the signal output loop. Also, the terminal device can also be used to re-configure the transmitter's set-up parameters: locally, or from a remote location.



The Measuring System

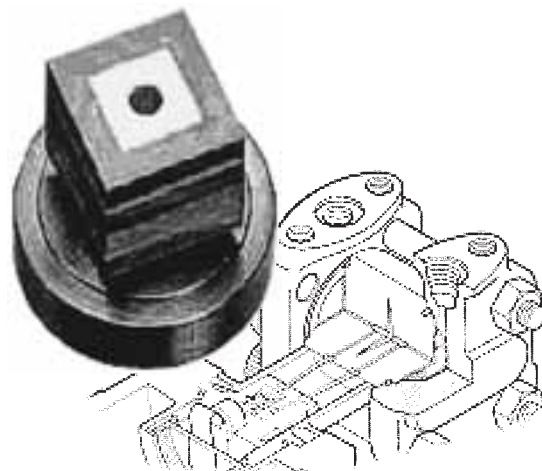

The ME 70 transmitter uses a precision silicon capacitance type pressure sensing element, which is manufactured under stringently controlled condition. This sensor is rugged, resistant to effects of fatigue and overloading, and unaffected by pressure fluctuations. The sensor and microprocessor based signal processing ensure the highest possible accuracy and stability.

Specifications

General

Measuring ranges _____ 0– 130 mbar to 0– 1.3 bar. Max. static pressure: 5 bar
0– 500 mbar to 0– 5 bar. Max. static pressure: 15 bar
0– 3 bar to 0– 30 bar. Max. static pressure: 90 bar
0– 10 bar to 0– 100 bar. Max. static pressure: 150 bar

Linearity _____ < 0.1%
Hysteresis _____ < 0.1%
Temperature coefficient _____ < 0.5% / 10°K
Operating temperature ambient _____ -10° to +70°C.
Operating temperature media _____ 0° to +80 °C
Protection Class _____ IP 67

Electrical

Supply voltage _____ 24 V DC (15 – 30 V DC)
Power consumption _____ Approx. 2 W
Dielectric strength _____ 500 V AC
Output signal _____ 4 – 20 mA. Optional: HART® interface, using
communication module (option -K: see ordering code)
Output load _____ Max. 600 Ohm (minimum 250 Ohms with communication
module installed)
Output current limit _____ 25 mA

Built-in display (optional) _____ Analog display with 0-100% scale
Digital display (only with communication Module
option -K installed)

Connections

Electrical connections _____ Internal terminal block
Pressure connection _____ 1/2" NPT(F) threaded socket

Materials

Parts in contact with media _____ Stainless steel 316 L (1.4404)
Seals _____ Viton. optional: teflon
Electronics housing _____ Aluminium (surface coated)

CE marking _____ The ME 71 transmitter carries the CE mark,
and complies with EMV specifications
EN 50082–1 and EN 50082–2

Dimensional Drawings

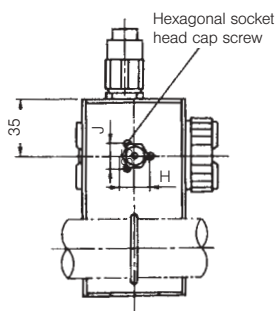
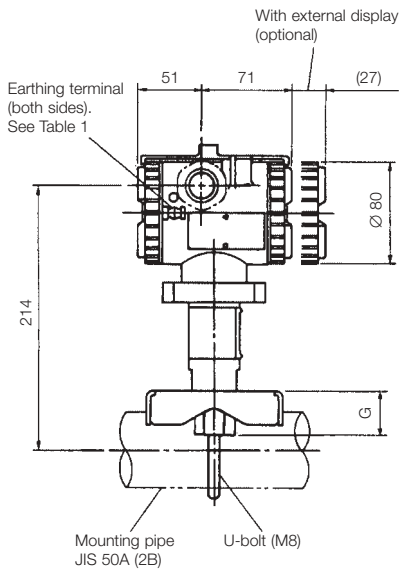
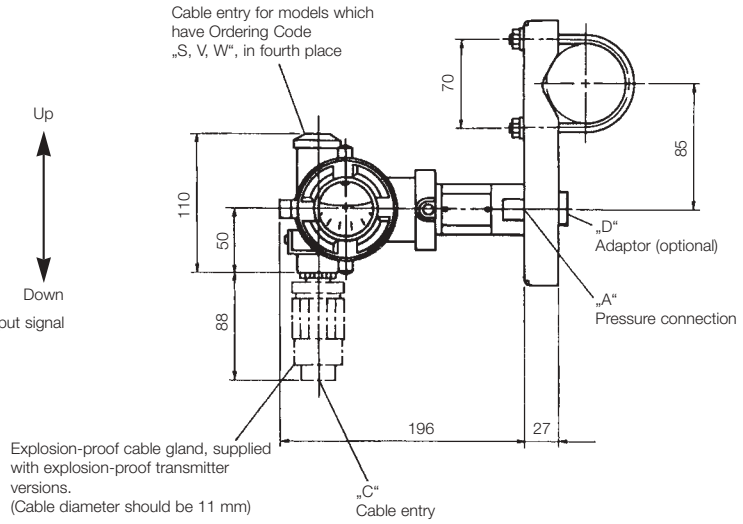
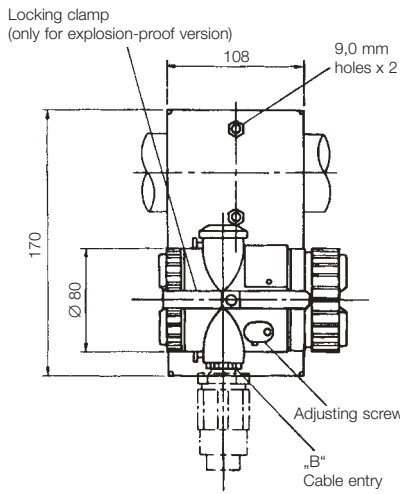

Electrical connections

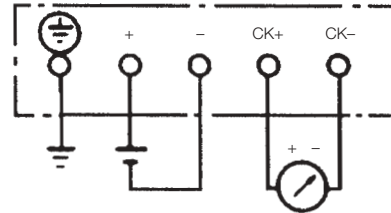

Ordering Code

Type ME 71 **V** **O** **Y** **O**

Communication Module

Without communications module▷ H
With communications module▷ K

Electrical connection: PG 13.5

Range

0- 130 mbar to ... 1.3 bar▷ 1 V
0- 0.5 bar to ... 5 bar▷ 2 V
0- 3 bar to ... 30 bar▷ 3 V
0- 10 bar to ... 100 bar▷ 4 V

Display

Without display▷ A
With analog display scale 0-100%▷ B
With digital display (only with option -K installed)▷ L

Hazardous location approval

Not approved for hazardous locations▷ A
Intrinsically safe per E Ex i a II C T4/T5▷ K
Explosion-proof per Ex d II C T5/T6▷ X

Mounting bracket kit

Without mounting bracket kit▷ A
With mounting bracket kit (stainless steel)▷ C

Instrument tag plate

Without tag plate▷ Y
Stainless tag plate with customer application data▷ B

Sensor filling liquid

Silicone oil▷ Y
Fluorinated oil for oxygen service▷ A

Pressure connection: 1/4 NPT inside 7/16.UNF

Simplifying Technology

Redefining Value...



OASIS INSTRUMENTS CO.

2-2-103 to 108 Ranigunj
Ganesh Chamber, 2nd Floor
Secunderabad - 500 003
Andhra Pradesh, India
Telefax: +91-40-40025290

E-mail : oasis_instruments@yahoo.co.in, info@oasisinstruments.com
Url: www.oasisinstruments.com